

Name: _____ ()

Parent's Signature: _____

Class: Pr. 4 _____

Date: _____

Total time for Section A and B: 40 minutes

Section A: Multiple-Choice Questions (9 x 2 = 18 marks)

For Questions 1 to 9, choose the most suitable answer and shade its number in the OAS provided.

1. Study diagrams A, B, C and D. Each represents a stage in the life cycle of a butterfly.

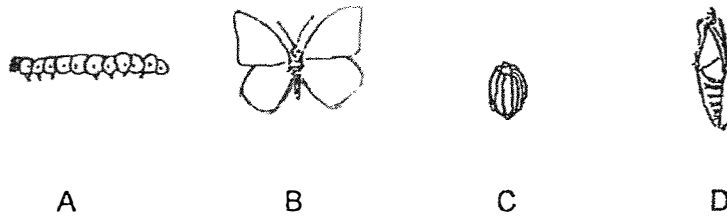

Which of the following options shows the correct life cycle of a butterfly?

(1)

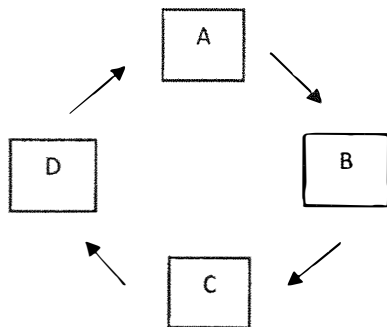

(2)

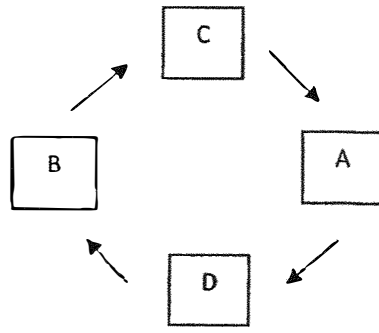

(3)

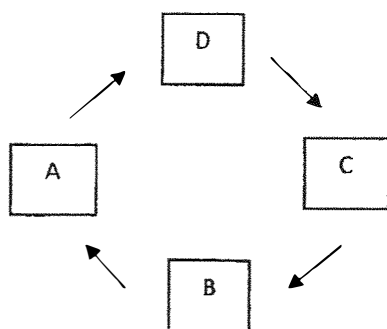

(4)

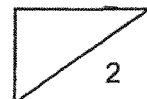
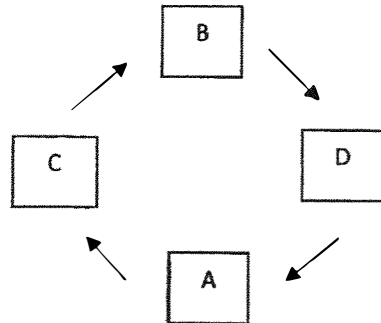

2. During a Science lesson, some students observed Animal Z.
The following observations were made about Animal Z.

Observation	Animal Z
Eggs are laid in water.	X
Has a pupa stage.	✓
The young looks like its adult.	X
The adult has wings.	✓

Key ✓ = Yes X = No

Based on their observations above, what could Animal Z be?

- A: Mosquito
- B: Beetle
- C: Cockroach
- D: Bird

- (1) B only
- (2) A and B only
- (3) B and C only
- (4) A and D only

3. A magnet can be made from _____.

- (1) iron and copper
- (2) plastic and steel
- (3) iron and steel
- (4) any metal

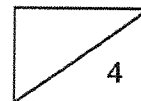

4. The diagram below shows a toy car with a magnet attached to its back. Object A is attached to a stick. When the stick is placed near the back of the car, the car moves forward and away from the object.

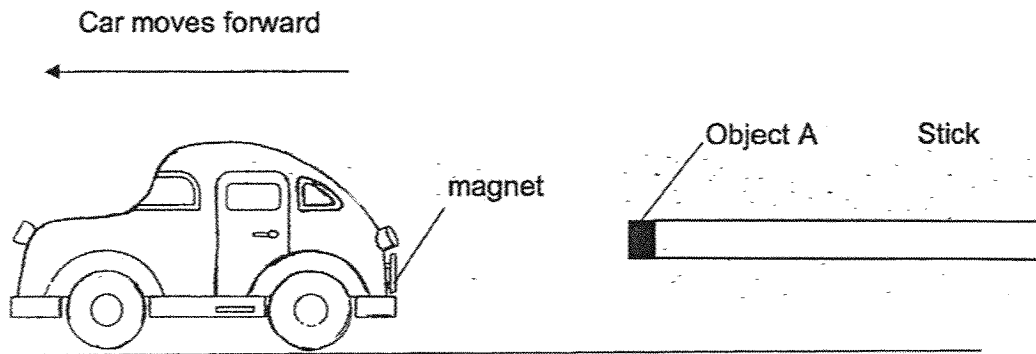

What could Object A be?

- (1) Battery
 - (2) Magnet
 - (3) Steel button
 - (4) Eraser
5. The diagram below shows two setups. Observe the interaction between Z, W and Y.

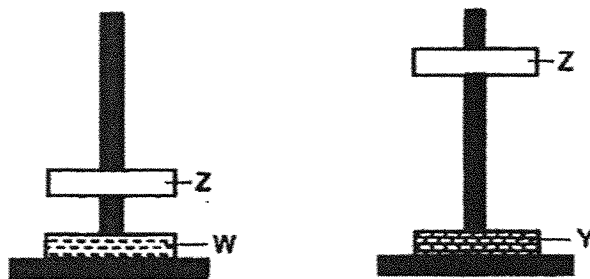

Which of the following statements is correct?

- (1) W, Y and Z must be made from iron.
- (2) Y has a stronger magnetic strength than W.
- (3) Z has a stronger magnetic strength than Y.
- (4) W has a stronger magnetic strength than Z.

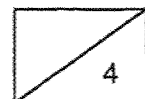

6. Which of the following is/are a source(s) of light?

A: Star

B: Sun

C: Moon

D: Unlit candle

(1) A only

(2) A and B only

(3) A, B and C only

(4) B, C and D only

7. A periscope is used to see items at a greater height.

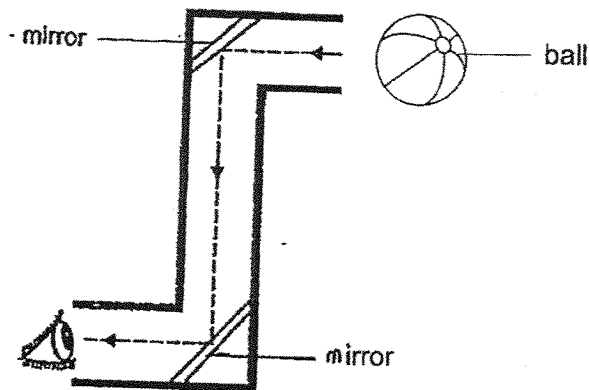

Which of the following explains why the user can see the ball?

A: Light travels in straight lines.

B: Light can be reflected.

C: Light travels from a higher place to a lower place.

D: Light can pass through transparent objects.

(1) A only

(2) B only

(3) A and B only

(4) B, C and D only

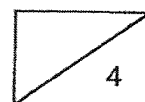

8. Holes are cut in sheets A and B as shown in the diagram below. Both sheets are of the same thickness and height.

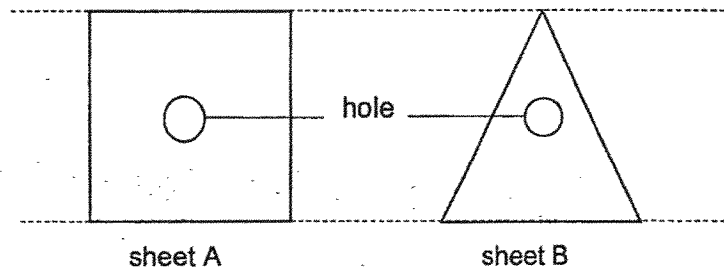

Sheets A and B are then pasted together and a light is shone on them.

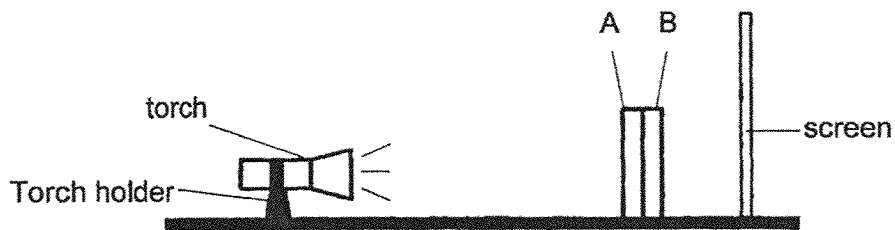

A shadow is cast on the screen as seen below.

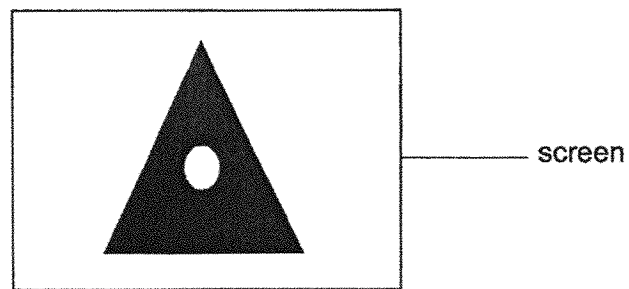

Based on the shadow formed, which of the following correctly represents the materials used to make Sheets A and B?

	Sheet A	Sheet B
(1)	frosted glass	cardboard
(2)	clear plastic	clear glass
(3)	metal plate	wooden board
(4)	clear glass	rubber sheet

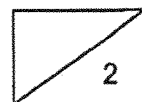

9. Which of the following is not a source of heat?

- (1) A lit bulb
- (2) A lighted match
- (3) A lighted candle
- (4) A ceramic cup

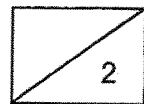

Section B: Open-ended Questions (3 x 4 = 12 marks)

10. The setup below can separate magnetic materials from non-magnetic materials. A mixture is poured down onto the roller belt. As the roller belt rolls to the right, the magnetic and non-magnetic materials are separated.

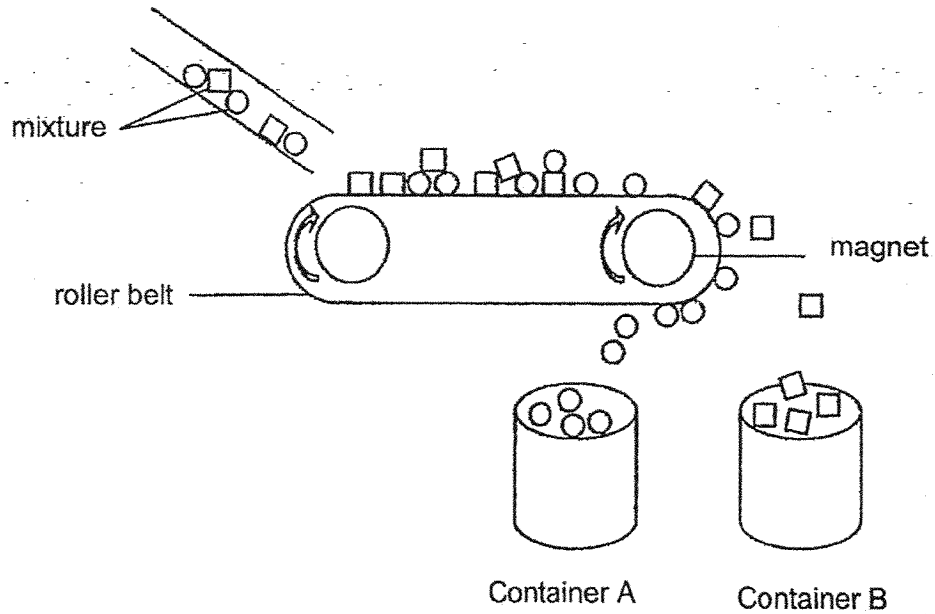

- (a) Give an example of a non-magnetic material. (1m)

- (b) What will containers A and B contain?

Fill in the table with 'magnetic materials' or 'non-magnetic materials'. (1m)

Container	Material
Container A	
Container B	

- (c) Can this setup separate iron nails and steel blocks? Explain your answer. (2m)

11. (a) What is the difference between heat and temperature? (2m)

(b) Anita was outdoors during winter. She felt very cold and decided to put on a jacket. She felt warmer after putting on a jacket.

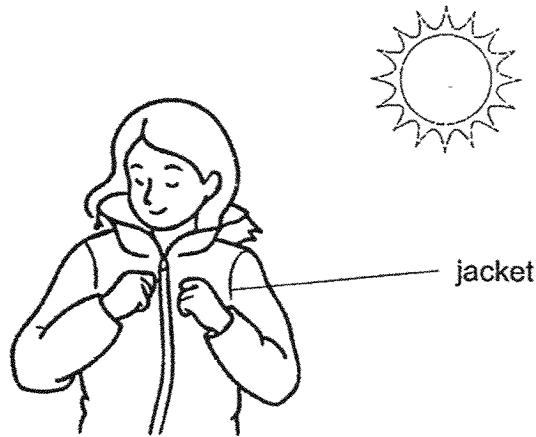

Anita said that the jacket was a source of heat, thus she felt warm. Is she correct? Explain your answer. (2m)

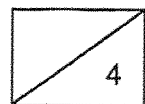

12. (a) How is a shadow formed? (1m)

(b) Mr Tan wanted to find out which material, X, Y or Z, reflects the most light. He did a setup as shown below. He turned on the torch and measured the amount of light reflected by Material X. He repeated the experiment using Material Y and Z.

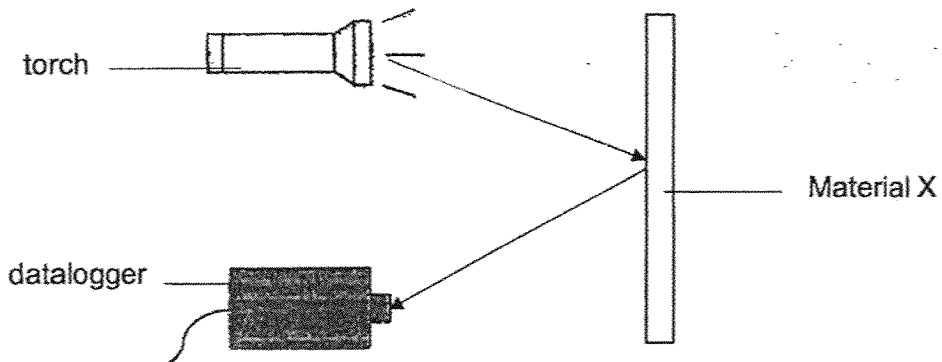

Material	Amount of light measured by datalogger (lux)
X	0
Y	100
Z	1800

Based on the results, which material reflects the most light? (1m)

(c) Which material is the most suitable to make a safety vest used by workers at night? Explain your answer. (2m)

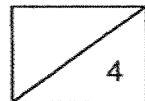

End of Paper
Please check your answer.

SCHOOL : RED SWASTIKA PRIMARY SCHOOL
LEVEL : PRIMARY 4
SUBJECT : SCIENCE
TERM : 2025 WEIGHTED ASSESSMENT 2

Q1	2
Q2	1
Q3	3
Q4	2
Q5	2
Q6	2
Q7	3
Q8	4
Q9	4
Q10)	a) Aluminium b) A: magnetic materials B: non-magnetic materials c) No. Both the iron and steel are magnetic materials. They will both be attracted by the magnet and fall into container A.
Q11)	a) Heat is a form of energy but temperature of an object is a measurement of how hot or cold something is. b) The jacket does not give off its own heat, so it is not a source of heat.
Q12)	a) A shadow is formed when light is complete or partially blocked by object. b) Z. c) Z. Z reflects the most light, so the safety vest on the worker will be seen the most clearly at night.

